

# Altivar™ 212 Drive

## Selection Guide

Variable speed drives for asynchronous motors used in centrifugal pump and fan applications



Make the most of your energy<sup>SM</sup>

**Schneider**  
Electric™

# Altivar 212 Drive Selection

- The Altivar 212 drive is intended for use with three-phase asynchronous motors for variable torque pump and fan applications.
- Select the Altivar 212 drive using the nameplate voltage and full load ampere rating of the motor nameplate and the table below.
- The Altivar 212 drive includes 3 logic inputs, 2 analog inputs, 1 analog output and 2 relay outputs (with 1 NO and 1 NO/NC contacts).
- It includes integrated 4 digit, 7 segment LED display with 7 button keypad, as well as RJ45 Modbus™ port, plus a 4 screw removable terminal block for software selectable BACnet, Modbus, METASYS N2 or APOGEE P1 communication protocols. LonWorks is available in an option card.

## Altivar 212 Drive Selection

AC Input line voltage				Enclosure rating							
	Three-phase motor power		Continuous Output current	IP 20 Open style product			Type 1 conduit kit (purchase ATV212 and conduit Kit for Type 1 installation)		Type 12/IP54		
	HP	kW	A	Catalog number	QTY	Frame size	Catalog number	QTY	Catalog number <sup>c</sup>	QTY	Frame size
208/240 Vac three-phase	1	0.75	4.6	ATV212H075M3X		1	VW3A31814		—		
	2	1.5	7.5	ATV212HU15M3X		1	VW3A31814		—		
	3	2.2	10.6	ATV212HU22M3X		1	VW3A31814		—		
	4	3	13.7	ATV212HU30M3X		2	VW3A31815		—		
	5	4	18.7	ATV212HU40M3X		2	VW3A31815		—		
	7.5	5.5	24.2	ATV212HU55M3X		3	VW3A31816		—		
	10	7.5	32	ATV212HU75M3X		3	VW3A31816		—		
	15	11	46.2	ATV212HD11M3X		4	VW3A31817		—		
	20	15	61	ATV212HD15M3X		4	VW3A31817		—		
	25	18.5	74.8	ATV212HD18M3X		4	VW3A31817		—		
	30	22	88	ATV212HD22M3X		5	VW3A9206		—		
40	30	117	ATV212HD30M3X		7	VW3A9208		—			
380/480 Vac three-phase	1	0.75	2.2	ATV212H075N4		1	VW3A31814		ATV212W075N4		1
	2	1.5	3.7	ATV212HU15N4		1	VW3A31814		ATV212WU15N4		1
	3	2.2	5.1	ATV212HU22N4		1	VW3A31814		ATV212WU22N4		1
	4	3	7.2	ATV212HU30N4		2	VW3A31815		ATV212WU30N4		2
	5	4	9.1	ATV212HU40N4		2	VW3A31815		ATV212WU40N4		2
	7.5	5.5	12	ATV212HU55N4		2	VW3A31815		ATV212WU55N4		2
	10	7.5	16	ATV212HU75N4		3	VW3A31816		ATV212WU75N4		2
	15	11	22.5	ATV212HD11N4		3	VW3A31816		ATV212WD11N4		3
	20	15	30.5	ATV212HD15N4		4	VW3A31817		ATV212WD15N4		3
	25	18.5	37	ATV212HD18N4		4	VW3A31817		ATV212WD18N4		4
	30	22	43.5	ATV212HD22N4S <sup>c</sup>		4	VW3A31817		—		
	30	22	43.5	ATV212HD22N4		5	VW3A9206		ATV212WD22N4		5
	40	30	58.5	ATV212HD30N4		5	VW3A9206		ATV212WD30N4		5
	50	37	79	ATV212HD37N4		6	VW3A9207		ATV212WD37N4		6
	60	45	94	ATV212HD45N4		6	VW3A9207		ATV212WD45N4		6
	75	55	116	ATV212HD55N4		7	VW3A9208		ATV212WD55N4		7
100	75	160	ATV212HD75N4		7	VW3A9208		ATV212WD75N4		7	



ATV212HU15N4



ATV212W075N4



ATV212HU55M3X



ATV212HD37N4



ATV212HU30M3X



ATV212HD37N4

- These horsepower, kW and continuous ampere ratings apply to default switching frequency and maximum 40° C ambient.
- Refer to the installation manual for derating curves as a function of switching frequency, ambient temperature and mounting conditions.
- IP20 Altivar 212 drives can be installed as UL Type 1 with the optional conduit box when following instruction in the Installation Manual.
- To select an Altivar 212W... drives with Class B EMC filter, add the letter "C" to the end of the standard catalog number.
- <sup>c</sup> Late 3Q 2011 availability.

## Altivar 212 Accessories and Options

User interface options	For use with	Catalog number	QTY
Remote LCD display keypad	Altivar 212, 312, 32 , 61, 71	VW3A1101	
8 line, 24 characters per line, plain text, 8 keys, rotary wheel, 60°C IP54 rated	—	—	
Remote LCD keypad mounting accessories	—	—	
IP54 rated kit for remote mounting LCD keypad on enclosure door	VW3A1101	VW3A1102	
Clear plastic door for use with VW3A1102 for IP65 rating and tamper resistance	VW3A1102	VW3A1103	
Female/Female right angle RJ45 adaptor, to connect cable and keypad.* (*not required if using VW3A1102)	VW3A1101	VW3A1105	
Remote LCD keypad mounting cables – equipped with two RJ45 connectors	—	—	
1 meter length	VW3A1101	VW3A1104R10	
3 meter length	VW3A1101	VW3A1104R30	
5 meter length	VW3A1101	VW3A1104R50	
10 meter length	VW3A1101	VW3A1104R100	
Multi-loader	Altivar 12, 212, 312, 32 Altistart 22	VW3A8121	
Use to copy configurations between like drives, PC Soft or SoMove PC software	—	—	
Software	For use with	Catalog number	
PCSoft	Altivar 21 and 212	Download at <a href="http://www.schneider-electric.us/go/drives">www.schneider-electric.us/go/drives</a>	
PC software use for: configuring, monitoring and trouble shooting Altivar 212 drives Requires one of two cables (noted below) to connect a PC to the RJ45 Modbus port on the drive	—	—	
USB/RS485 cable: equipped with USB connector and RJ45 connector	Altivar and Altistart	TCSMCNAM3M002P	
RS 232-RS485 converter with SUB-D and RJ45 port, cable with two RJ45 connectors	Altivar 212	VW3A8106	
SoMove™ Mobile	Altivar 212	Download at <a href="http://www.schneider-electric.us/go/drives">www.schneider-electric.us/go/drives</a>	
Software for compatible mobile phones provides wireless interface similar to the LCD display Requires Modbus to Bluetooth adaptor to connect phone and Altivar 212 drive	—	—	
Modbus – Bluetooth adaptor: connects to RJ45 Modbus port on the drive	Altivar 12, 212, 312,61, 71	VW3A8114	
Communication option	For use with	Catalog number	
LonWorks communication option card	Altivar 212	VW3A21212	
Provides 4 screw terminal block for connection to LonWorks network Install in place of standard control board that comes mounted in the Altivar 212 drive The I/O count is reduce to 3LI, 1 AI and 1 NO/NC relay	—	—	
Mounting kit	For use with	Catalog number	
DIN rail mounting kit	Altivar 212H075M3X... 22M3X and Altivar 212H075N4...22N4	VW3A31852	
For installation on to 35mm wide DIN rail	—	—	



VW3A1101



VW31101, VW31102,  
VW31103, VW3A1104R10



VW3A8121

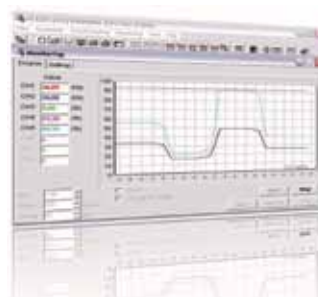

PCSoft™ Software



SoMove™  
Mobile Software



VW3A21212

# Altivar 212 Drive Technical Characteristics

Environmental Specifications	
Temperature ratings	0 to + 40°C operational without de-rating, up to 60°C with de-rating (see installation manual for deratings)
Altitude ratings	Up to 3,300 ft (1,000 meters) without de-rating, de-rate nominal current by 1% for each additional 330 ft ( 100m) up to 10,000 ft ( 3,000 m) Limit to 6,600 ft (2,000 m) if supplied by corner grounded distribution system
Humidity	Up to 95% non-condensing , IEC 60068-2-3
Vibration resistance	1.5 mm peak to peak from 3 to 13 Hz conforming to EN/IEC 600068-2-6, 1 gn from 13 to 200 Hz conforming to IEC/EN 60068-2-8
Shock resistance	15 gn for 11 ms conforming to IEC/EN 60068-2-27
Pollution degree	1 HP to 25 HP @ 200/240 V, 1 HP to 5 HP @ 380/480 V: Pollution degree 2 per IEC/EN 61800-5-1, 30 HP to 40 HP @ 200/240 V, 30 HP to 100 HP @ 380/480 V: Pollution degree 3 per IEC/EN 61800-5-1
Degree of protection: ATV212 H range ATV212 W range	IP20, Conformal coating per IEC 60721-3-3 classes 3C2 and 3S2, Type 1 with optional conduit kit IP54/Type 12, Conformal coating per IEC 60721-3-3 classes 3C2 and 3S2
Electrical Specifications	
Input voltage and HP range ATV212 W is available in 380/480 range only	200 – 15% to 240 +10%, Three phase input, Three phase output, 1 HP to 40 HP 380 – 15% to 480 +10%, Three phase input, Three phase output, 1 HP to 100 HP
Input frequency	50 Hz -5% to 60 Hz +5%
Galvanic isolation	Galvanic isolation between power and control (inputs, outputs and power supplies)
Drive input power section	Six pulse bridge rectifier
Drive output power section	IGBT inverter with pulse width modulated output
Power factor	Above 99%
Efficiency	Above 98% at full load
Switching frequency	Selectable from 6 to 16 kHz, 12 kHz nominal rating for 1 HP to 20 HP @ 200/240 V, 380/480 V Selectable: 6 to 16 kHz, 8kHz nominal rating for 30 HP to 40 HP @ 200/240 V, 30 HP to 100 HP @ 380/480 V
Acceleration and deceleration ramps	0.1 to 3200 seconds in 0.1 seconds increments
Frequency output range	0.5 to 200 hertz
Skip frequencies	Three adjustable skip frequency bands
Speed range	1 to 10
Integrated motor protection	Class 10 electronic overload protection
Asynchronous motor control profiles	Sensorless flux vector, 2 point volts/hertz, quadratic volts/hertz, energy savings mode: a optimization motor algorithm that automatically optimizes voltage based on load
Transient over current	110% nominal for 60 seconds, 180% for 2 seconds
Embedded functions	Over 50 functions dedicated to pump and fan applications
User interface	On board: 5 LED indicators for various functions, 4 digit, 7 segment LED display with 7 button keypad for: Run, Stop/Reset, Local/remote, Speed up, speed down, Mode selection and Enter. Quick start menu, fault history, I/O mapping, last-used menus, status monitoring and self diagnostics. Fault messages and status such as: power on time, elapsed time, motor run time, line voltage, motor current, ready to run, running, motor speed, etc.
Embedded communication	Embedded RJ45 port for remote keypad connection, Multi-loader, PC software, or Bluetooth dongle for So Mobile smart phone connection. Embedded 4 screw removable terminal for daisy chain connection for: Modbus, BACnet, Metesys N2, or Apogee P1 communication networks.
Harmonic abatement	Embedded reduced harmonic technology provides <35% THDI at VFD input terminals, which is equivalent to a 3% line reactor or DC choke. See technical paper 8800DB0702 for more information.
EMC compliance: ATV212 H and W N4 range: ATV212 W N4C range: ATV212H M3X range:	Integrated Class 2 EMC filter for radiated and conducted emissions, IEC 61800-3, category C2 and C3 Integrated Class 2 EMC filter for radiated and conducted emissions, IEC 61800-3, category C1 No integrated EMC filter (use optional filters to reduce emission levels)
Compliance	UL 508C, RoHS, IEC 61800-5-1, IEC/EN61000-3-12 THDI harmonic standard
Certifications	UL File E116875, CSA 2278406, UL 508C, Plenum rated per UL508C for UL1995 installations, C-Tick, NOM 117, CE marked

# Altivar 212 Inputs/Outputs Electrical Characteristics

Default function setting	Function	Terminals	Characteristics
—	External power supply input	PLC	+24 Vdc input for external power supply for logic inputs Max. permissible voltage: 50 Vdc
	Internal supply	P24	Short-circuit and overload protection: 24 Vdc supply (min. 21 Vdc, max. 27 Vdc), maximum current: 200 mA
	Common	CC	0 Vdc common (2 terminals)
Fault relay	Configurable relay outputs	FLA FLB FLC	1 relay logic output, 1 N/C contact, and 1 N/O contact with common point Minimum switching capacity: 10 mA for 5 Vdc Maximum switching capacity: <ul style="list-style-type: none"> <li>On resistive load (<math>\cos \varphi = 1</math>): 5 A for 250 Vac or 30 Vdc</li> <li>On inductive load (<math>\cos \varphi = 0.4</math> and <math>L/R = 7</math> ms): 2 A for 250 Vac or 30 Vdc</li> </ul> Max. response time: 10 ms
Speed attained		RY RC	1 relay logic output, 1 N/O contact Minimum switching capacity: 3 mA for 24 Vdc Maximum switching capacity: <ul style="list-style-type: none"> <li>On resistive load (<math>\cos \varphi = 1</math>): 3 A for 250 Vac or 30 Vdc</li> <li>On inductive load (<math>\cos \varphi = 0.4</math> and <math>L/R = 7</math> ms): 2 A for 250 Vac or 30 Vdc</li> </ul> Max. response time: 7 ms $\pm$ 0.5 ms
F: Run forward R: Preset speed at 15 Hz RES: Reset	Configurable logic inputs	F R RES	3 programmable logic inputs, 24 Vdc, compatible with level 1 PLC, IEC 65A-68 standard Impedance: 4.7 k $\Omega$ Maximum voltage: 30 Vdc Max. sampling time: 2 ms $\pm$ 0.5 ms Multiple assignment makes it possible to configure several functions on one input Positive logic (Source): State 0 if $\leq 5$ Vdc or logic input not wired, state 1 if $\geq 11$ Vdc Negative logic (Sink): State 0 if $\geq 16$ Vdc or logic input not wired, state 1 if $\leq 10$ Vdc
Output frequency	Configurable analog output	FM	1 switch-configurable (SW101) voltage or current analog output: <ul style="list-style-type: none"> <li>Voltage analog output 0–10 Vdc, minimum load impedance 7.62 k<math>\Omega</math></li> <li>Current analog output X–Y mA by programming X and Y from 0 to 20 mA, maximum load impedance: 970 <math>\Omega</math></li> </ul> Max. sampling time: 2 ms $\pm$ 0.5 ms Resolution: 10 bits Accuracy: $\pm 1$ % for a temperature variation of 60° C Linearity: $\pm 0.2$ %
—	Internal supply available	PP	Short-circuit and overload protection: One 10.5 Vdc $\pm$ 5% supply for the reference potentiometer (1 to 10 k $\Omega$ ), maximum current: 10 mA
Primary speed reference, 0–10 V	Configurable analog/logic input	VIA	Switch-configurable voltage or current analog input: <ul style="list-style-type: none"> <li>Voltage analog input 0–10 Vdc, impedance 30 k<math>\Omega</math> maximum voltage: 24 Vdc</li> <li>Analog current input X–Y mA by programming X and Y from 0 to 20 mA, with impedance 250 <math>\Omega</math></li> </ul> Max. sampling time: 3.5 ms $\pm$ 0.5 ms Resolution: 10 bits Accuracy: $\pm 0.6$ % for a temperature variation of 60° C Linearity: $\pm 0.15$ % of the maximum value This analog input is also configurable as a logic input Consult the Altivar 212 Programming Manual for more information
Secondary speed reference, 1–10 V	Configurable analog input	VIB	Voltage analog input, configurable as an analog input or as a PTC probe input Voltage analog input: <ul style="list-style-type: none"> <li>0–10 Vdc, impedance 30 k<math>\Omega</math> max. voltage 24 Vdc</li> <li>Max. sampling time: 22 ms <math>\pm</math> 0.5 ms</li> <li>Resolution: 10 bits</li> <li>Accuracy: <math>\pm 0.6</math>% for a temperature variation of 60 °C</li> <li>Linearity: <math>\pm 0.15</math>% of the maximum value</li> </ul> PTC probe input: <ul style="list-style-type: none"> <li>6 probes max. mounted in series</li> <li>Nominal value &lt; 1.5 k<math>\Omega</math></li> <li>Trip resistance 3 k<math>\Omega</math>, reset value 1.8 k<math>\Omega</math></li> <li>Short-circuit detection threshold &lt; 50 <math>\Omega</math></li> </ul>
—	Graphic display terminal or Modbus	RJ45	Used to connect graphic display terminal or connect the drive to a Modbus fieldbus Note: for using Modbus on the RJ45, modify parameter F807 (see Modbus manual)
—	Fieldbus	Open style connector	Refer to communication manual related to the fieldbus

# Altivar 212 Drive

Integrated Fan and Pump Functionality	
Run command	Input to drive by remote contact from the BAS, 24 vdc supplied by VFD
Speed command	Input to drive from the BAS; typically 4-20mA dc or 0-10 Vdc
Run status	Output contact from drive to the BAS; 1 N.O. contact on drive
Speed feedback	Analog output from drive to the BAS; typically 4-20mA dc, or assignable to meter values
Fault Output	Output contact from drive to the BAS; 1 N.O. & 1 N.C. contact on drive
Loss of Speed	Configuration to run at last speed or a pre-defined speed on loss of speed command
Automatic Restart	Selectable configuration to automatically restart after cause of fault is cleared
Skip Frequency Bands	Three skip frequency settings with adjustable bandwidth to tune out resonating frequencies in piping or ductwork
Local/Remote Control	Keypad selectable: local keypad control for Run, Stop and speed control or from remote signal from BAS
Catch on the Fly	Configuration to initiate speed and direction search to provide smooth start of windmilling fans
Damper Control Relay	Output on the drive to control damper opening sequence, and wait for feedback to start the motor
Smoke Purge Override	Logic Input on the drive configured to run the motor at configured speed for forced ventilation
Broken Belt Detection	Configuration to detect under load condition and initiate alarm sequence
PID Control	Set point and feedback inputs for proportional, integral, and derivative control
Sleep/Wake-up	Configuration in the drive to stop the pump at low or no flow and re-start on demand for flow
Pump Jam Management	Configuration to manage blocked pump impeller
Motor direction protection	Configuration to prevent operation in reverse direction



## Typical air handling applications:

- HVAC supply and return fans
- Exhaust and ventilation fans
- Cooling tower fans
- Energy recovery wheels



## Typical pumping applications:

- Cooling tower pumps
- Chilled water and hot water pumps
- Fountain pumps
- Domestic water supply pumps

# Altivar 212 Drive Dimension and Weights

Electronic 2D sales drawings with specifications and 3D CAD models available at [www.schneider-electric.us/go/CAD](http://www.schneider-electric.us/go/CAD)

IP20 drives									UL Type 1			
Frame size	a – Width		b – Height		c – Depth		Approximate weight		d – Height with Type 1 conduit kit		Weight with Type 1 conduit kit	
	mm	in.	mm	in.	mm	in.	kg.	lbs.	mm	in.	kg.	lbs.
1	105	4.13	143	5.63	150	5.91	1.2	2.65	194.5	7.66	2.1	4.65
2	140	5.51	184	7.24	150	5.91	2.4	5.29	236	9.29	3.53	7.79
3	180	7.09	232	9.13	170	6.69	4.7	10.36	311	12.24	6.05	13.36
4	245	9.65	329.5	12.97	190	7.48	7	15.44	401	15.79	7.23	15.94
5	240	9.45	420	16.54	213	8.39	9	19.85	480	18.89	10.59	23.35
6	240	9.45	550	21.65	244	9.61	38.1	84.01	610	24.01	39.92	88.01
7	320	12.60	630	24.80	289.9	11.41	55.4	122.16	833	32.80	57.68	127.16

Frame 1 and 2

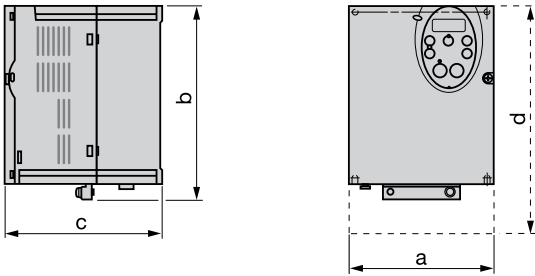

Frame 3 and 4

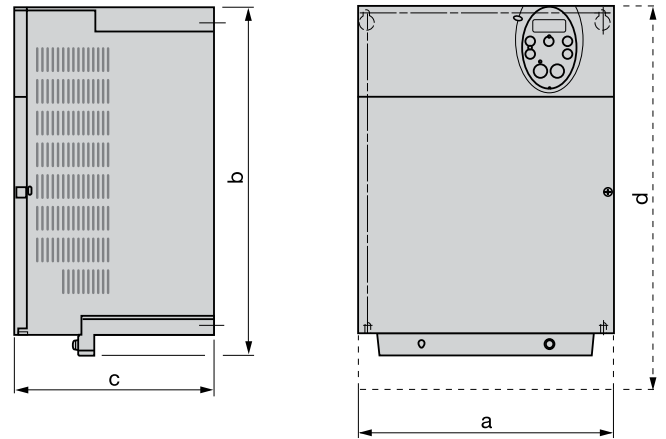

Frame 5 and 6

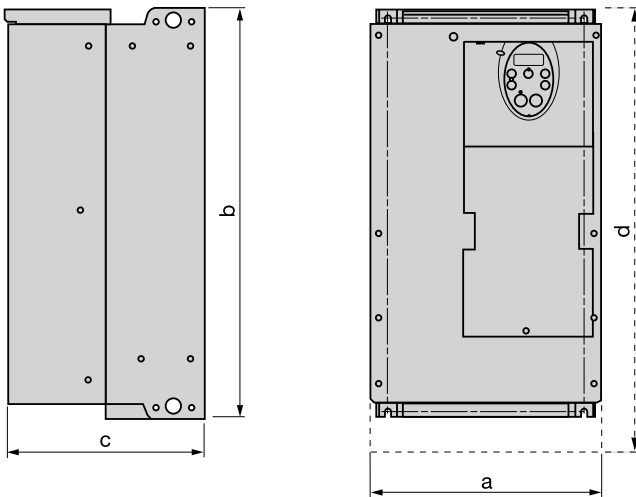

Frame 7

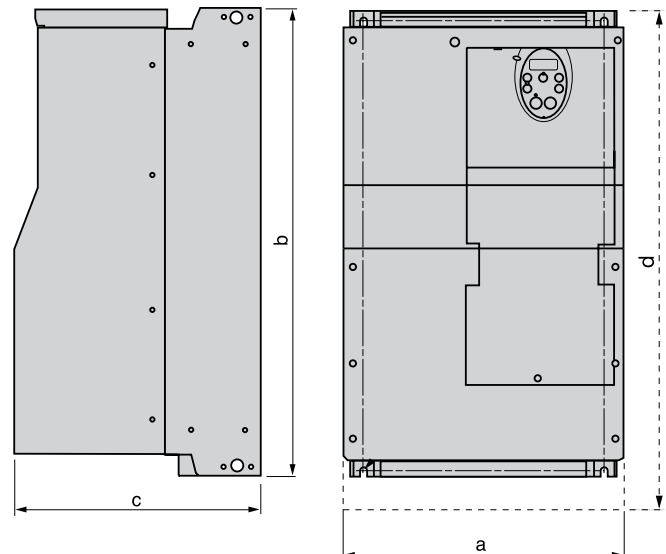

# Altivar 212W Drive Dimension and Weights

## IP54 drives

Frame size	a – Width		b – Height		c – Depth		Appr. weight	
	mm	In.	mm	In.	mm	In.	kg.	lbs.
1	215	8.46	297	11.69	192	7.56	7	15.44
2	230	9.06	340	13.39	208	8.19	9.65	21.28
3	290	11.42	560	22.05	315	12.40	30.3	66.81
4	310	12.20	665	26.18	315	12.40	37.4	82.47
5	284	11.18	720	28.35	315	12.40	49.5	109.15
6	284	11.18	880	34.65	343	13.59	57.4	126.57
7	362	14.25	1000	39.51	364	14.33	61.9	136.49

### Frame 1 and 2

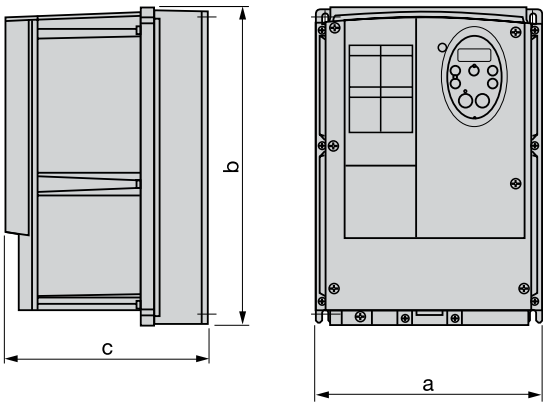

### Frame 3 to 7

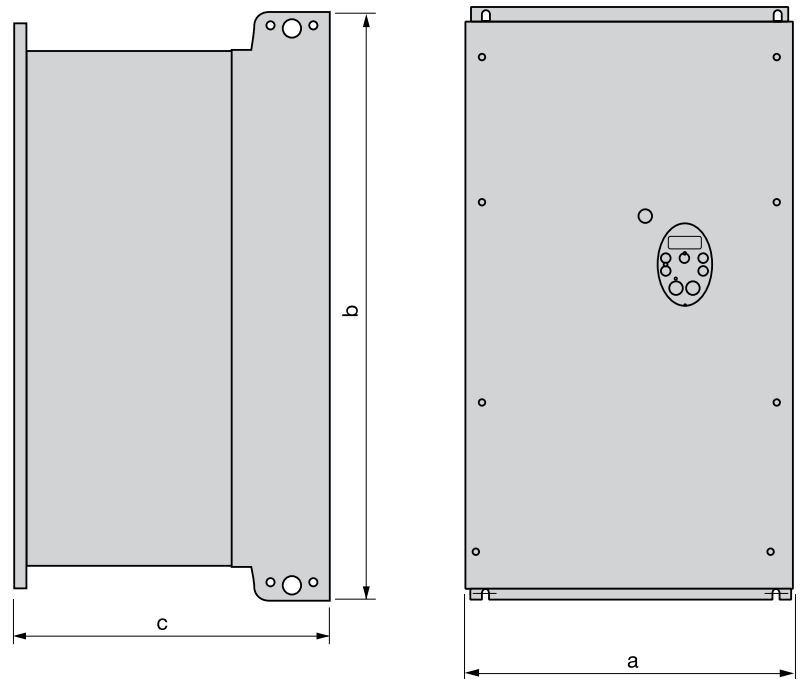

Schneider Electric USA, Inc.

Schneider Electric Canada, Inc.

 This document has been printed on recycled paper